

REHANDLING CLAMSHELLS

HOSE PROTECTION

Protection shield on rotate motor for hose connectors

ROTATION MOTOR

Fully protected compact rotary motor, endless hydraulic rotation with integrated pressure limitation

CUTTING EDGES

Side and bottom cutting edges are manufactured from high-strength fine-grain steel, reinforced with Hardox HB500 profiles

SHELLS

Made from high-strength fine-grain steel. Shells are interchangeable throughout each model

SHELL COVERS (OPTIONAL)

Available with steel covers when handling light materials

PRODEM REHANDLING CLAMSHELL GRABS ARE CLASS LEADING IN INGENUITY AND PERFORMANCE, OFFERING A RANGE OF VOLUMES FROM 1000 TO 8000 LITRES. THE RCS RANGE WILL GIVE THE OPERATOR MAXIMUM CONTROL OF ANY REHANDLING APPLICATION.

PRODEM ARE ABLE TO OFFER CUSTOMISED GRABS TO SUIT EACH CUSTOMER'S APPLICATION AND REQUIREMENTS.

THE PRODEM RCS CLAMSHELLS HAVE A VERY HIGH CLOSING FORCE AND QUICK CYCLE TIMES. WE RELY HEAVILY ON OUR FLEET OF PRODEM'S TO UNLOAD THE AGGREGATE TRAINS DAY & NIGHT.



TECHNICAL SPECIFICATION

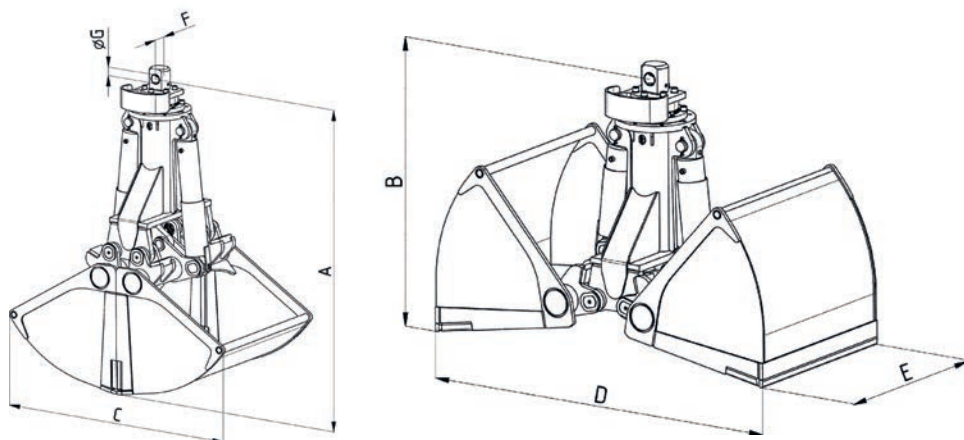

Model	Max. Grab Capacity (t)	Max. Rotation Load (t)	Material Weight Up (t/m ³)	Working Pressure - Rotation (bar)	Working Pressure - Open/Close (bar)	Max. Capacity - Rotation (l/min)	Max. Capacity - Open/Close (l/min)	Excavator Weight Class (t)
RCS4	4	15	2	140	300	35	110	12-21
RCS4/MH	4	15	2	140	300	35	110	18-25
RCS5	8	15	3	140	320	35	140	22-35
RCS5/MH	8	15	3	140	320	35	140	26-45
RCS6	12	25	3	200	320	50	170	36-50
RCS6/MH	12	25	3	200	320	50	170	46-80

Model	Capacity (l)	Weight (kg)	Shell Width E (mm)	Height A (mm) (Closed)	Height B (mm) (Open)	Width C (mm) (Closed)	Width D Opening (mm)	Rotator Connection Width F (mm)	Mounting Pin Diameter G (mm)
RCS4-1000	1000	1325	1100	2480	1780	1770	2130	114	70
RCS4-1200	1200	1400	1400	2480	1780	1770	2130	114	70
RCS4-1400	1400	1475	1600	2480	1780	1770	2130	114	70
RCS5-1500	1500	1900	1200	2500	1730	1980	2360	114	70
RCS5-2000	2000	2100	1600	2500	1730	1980	2360	114	70
RCS5-2500	2500	2300	2000	2500	1730	1980	2360	114	70
RCS6-2000	2000	2920	1200	3130	2120	2390	2860	149	80
RCS6-2500	2500	3100	1500	3130	2120	2390	2860	149	80
RCS6-3000	3000	3280	1800	3130	2120	2390	2860	149	80

* Grab design can be amended to suit customers requirements. * Larger models available upon request.