

HEAVY DUTY SELECTOR GRABS

PRODEM HEAVY DUTY SELECTOR GRABS ARE DESIGNED FOR SELECTIVE DEMOLITION, SORTING AND LOADING OF RECYCLABLE MATERIALS.

CONTINUOUS 360° HYDRAULIC ROTATION

Twin rotation motor ensures powerful and accurate equipment operation
(Twin motors PSG600-D upwards)

ROTATE MOTOR PROTECTION VALVES

SAFETY CHECK VALVE
To retain the grab force

**MAXIMUM CLOSING
AND GRAB FORCE**

UNIQUE FRAME DESIGN

Capable of maximum protection

WEAR RESISTANT QUALITY MATERIALS

Used for maximum durability and minimum downtime

REPLACEABLE CUTTING EDGE

For easy and cost saving maintenance

WIDE OPENING

For higher capacity

BENEFITS OF PRODEM DEMOLITION-SORTING GRABS

- » Low weight
- » Short height
- » Standard, reversible and changeable wear blades
- » Cylinders are motionless, therefore the hoses do not move (prevents wear out)
- » Cylinders with end damping
- » Long hinge arms to the cylinder for a greater closing power
- » Turning joints sealed with heavy duty turning joint seals
- » The grease nipples are easy to reach, direct into pin bushes
- » The PSG600-D upwards have 2 rotate motors which gives increased rotate power
- » One piece perforated shell skins manufactured from hardox – increased strength, lighter and more durable

“ I HAVE USED THE PRODEM SELECTOR GRABS NOW FOR MANY YEARS AND WOULD STRONGLY RECOMMEND THEM TO ANY USER. THEY’RE POWERFUL, EASY TO MAINTAIN AND SERVICE, STRONG AND STAND UP TO THE TOUGHEST JOBS. ”

TECHNICAL SPECIFICATION

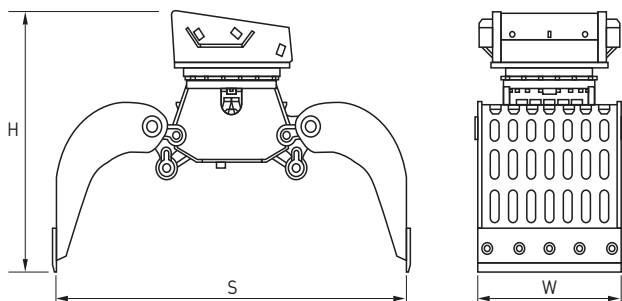

- >> High quality manufacturing and quick delivery times for grabs and parts.
- >> To suit 0.7 - 200 tonne Excavators

“ THE PRODEM PSG 13000-D IS THE WORLD’S LARGEST SELECTOR GRAB WEIGHING A MASSIVE 13 TONNES. ”

Model	Working Weight (kg)	Pressure - Open/Close (bar)	Oil Flow - Open/Close (lpm)	Min Pressure - Rotation (bar)	Max Pressure - Rotation (bar)	Oil Flow - Rotation - L/Min (mm)	Width W (mm)	Max Opening S (mm)	Height H (mm)	Capacity (l)	Closing Force (kn)	Excavator Weight Class (t)
PSG75-D	75	300	15	150	170	5	300	600	600	30	6	0.7-1.2
PSG150-D	140	300	25	150	170	10	450	750	700	70	15	1.2-3
PSG200-D	240	300	35	150	170	10	500	1160	850	100	20	2.5-5
PSG400-D	350	300	40	150	170	12	600	1400	950	150	23	4-8
PSG450-D	400	300	50	150	170	12	700	1500	1000	200	24	5-9
PSG500-D	600	350	90	190	210	15	600	1800	1150	300	30	7-12
PSG600-D	840	350	100	190	210	25	800	1800	1200	400	35	10-16
PSG800-D	1000	350	120	190	210	25	800	1950	1300	500	46	12-20
PSG900-D	1050	350	120	190	210	25	900	1950	1300	600	46	13-20
PSG1000-D	1100	350	120	190	210	25	1000	1950	1300	700	46	15-20
PSG1002-D	1170	350	120	190	210	25	1000	1950	1300	700	55	16-21
PSG1100-D	1400	350	150	190	210	35	900	2100	1500	750	55	16-24
PSG1202-D	1500	350	160	190	210	35	1000	2100	1500	800	68	17-28
PSG1402-D	1600	350	170	190	210	35	1200	2100	1500	850	68	20-28
PSG1900-D	2000	350	180	190	210	35	1200	2250	1650	900	80	25-38
PSG2500-D	2500	350	200	190	210	35	1200	2230	1700	1000	90	28-45
PSG2700-D	2700	350	200	190	210	35	1360	2230	1750	1100	90	30-50
PSG3000-D	3000	350	200	190	210	35	1500	2460	1800	1300	90	35-50
PSG5000-D	5000	350	300	190	210	60	1500	3000	2000	1600	130	45-100
PSG13000-D	13000	350	350	220	250	100	1800	4400	3000	4600	180	100-200