

# Orange Peel Grabs Heavy Duty with 1000 l / 1500 l / 2000 l Volume P51VHD

Orange peel grab with 4 or 5 tines and 1000 l / 1500 l / 2000 l volume for the handling of bulky scrap with excavators from 36t to 50t operating weight - for heavy duty tasks.

- Available in two different volumes and diverse tine profiles (see technical drawings below).
- Hydraulic cylinders are fitted with replaceable piston rod protection and are hydraulically cushioned.
- Oil distributor with integrated non-return valve mounted directly underneath the rotator.
- Oil distribution and hydraulic hoses are protected in the carrier.
- Greasing points are easily accessible.
- Reinforced tines made of wear-resistant steel HB 400.
- Weld-on tips made of high resistant forged and tempered steel HB 500.
- High closing force 33 kN at an operating pressure of 35 MPa.
- Accurate fittings eliminate tine distortion, solid end stops (open & close).
- Reinforced bolts, large bearing surface for bolts, specially coated solid steel bushings.
- Robust, fully integrated rotation with sturdy slewing ring with internal hoses guarantees optimum force transmission and prevents hose break. The integrated pressure relief valve protects against overcharge.
- Swivel and bevel sealed. Rotary feedthrough and motor accessible directly.

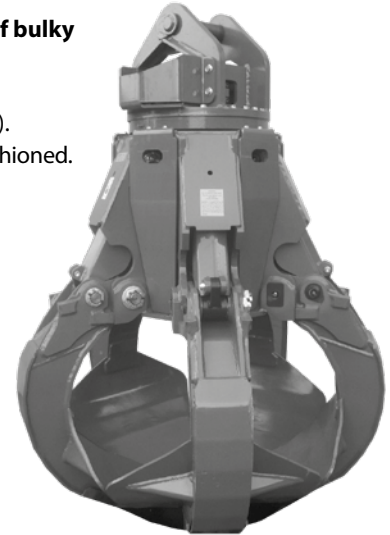

## Orange Peel Grabs P51VHD Heavy Duty

Type	Width A (closed) (mm)	Opening B (mm)	Height C (closed) (mm)	Volume (litre)	Number of tines	Weight (kg)	Load capacity (kg)
P51VHD-1000-4-W	1630	2440	2200	1000	4	1620	10000
P51VHD-1000-4-T	1630	2440	2200	1000	4	1595	10000
P51VHD-1000-5-F	1630	2440	2200	1000	5	2165	10000
P51VHD-1000-5-H	1630	2440	2200	1000	5	2000	10000
P51VHD-1000-5-W	1630	2440	2200	1000	5	1930	10000
P51VHD-1000-5-T	1630	2440	2200	1000	5	1890	10000
P51VHD-1500-5-F	1870	2840	2500	1500	5	2320	10000
P51VHD-1500-5-H	1870	2840	2500	1500	5	2155	10000
P51VHD-1500-5-W	1870	2840	2500	1500	5	2085	10000
P51VHD-1500-5-T	1870	2840	2500	1500	5	2045	10000
P51VHD-2000-4-W	2005	3055	2580	2000	4	1895	10000
P51VHD-2000-4-T	2005	3055	2580	2000	4	1860	10000
P51VHD-2000-5-F	2005	3055	2580	2000	5	2470	10000
P51VHD-2000-5-H	2005	3055	2580	2000	5	2305	10000
P51VHD-2000-5-W	2005	3055	2580	2000	5	2235	10000
P51VHD-2000-5-T	2005	3055	2580	2000	5	2195	10000

**Package consists of:** orange peel grab, integrated rotation with sturdy slewing ring, head plate, hose guard, non-return valve and bolt-on bottom plate with welded lifting eye

## Accessories

Type	Description
KM 501 19t-60t	upper suspension without pendulum damper
SW40 cardanic	adapter for Lehnhoff grab exchange system SW/HS40 without suspension – up to 70t adapter for quick exchange systems from other manufacturers available

## Requirements of Excavator

<b>Operating pressure:</b>	<b>Open/ Close</b> max. 35 MPa (350 bar)	<b>Rotation</b> max. 17 MPa (170 bar)
<b>Pump capacity:</b>	120 - 200 l/min	25 - 60 l/min
<b>Hydraulic connection:</b>	1"	1/2"

## Technical Drawings

